

Hybrid Fibre Reinforced Concrete under Fatigue Loading

N. Banthia¹, S. Cangiano², R. Cucitore², G.A. Plizzari³, L. Sorelli⁴

¹ University of British Columbia, 2324 Main Mall, V6T-1Z4 Vancouver BC, Canada
banthia@civil.ubc.ca

² C.T.G. – Italcementi Group, Via Camozzi 144, 24121 Bergamo, Italy
s.cangiano@itcgr.net

³ Università di Bergamo, via Marconi 5/A, 24044 Dalmine (BG), Italy plizzari@unibg.it

⁴ University of Brescia, via Branze 38, 25123 Brescia, Italy sorelli@ing.unibs.it

ABSTRACT. *Fibre reinforced concrete (FRC) is now used in special structures subjected to dynamic loads such as airport pavements, highways overlays, bridge decks and machine foundations.*

The cracking-related phenomena governing the fatigue of concrete underline the potential benefit of the presence of fibres. Recent investigations have shown that the combination of different fibre types (Hybrid Fibre Reinforced Concrete or HyFRC) provides a higher toughness. In a Hybrid system, microfibres provide reinforcement mechanisms at small to medium crack openings while macro-fibres would carry stresses across cracks at medium to large crack openings.

In this study the benefits caused by combination of micro and macro steel-fibres are evaluated under static and fatigue tests carried out on beams under four point bending and on cylinders under direct tension. The results show the mixture of fibre permits a more effective control of the dynamic crack development.

INTRODUCTION

The utilisation of High Strength Concrete remarkably increased in civil engineering constructions, such as bridges and offshore structures, and has allowed the reduction of self weight of the structures. As a consequence, this has emphasised the structural effects of the variable loads as well as the interest in the fatigue behaviour of concrete.

It is well known that cracks or microcracks are often present in concrete structural elements due to drying shrinkage or thermal gradients; therefore, the correct design of structural elements subjected to variable loads may need a preliminary investigation on the fatigue behaviour of cracked concrete [1].

The cracking-related phenomena governing the fatigue of concrete underline the potential benefit of the presence of fibres [2]. The use of fibres should be even more effective in High Strength Concrete (HSC) which increases its toughness and becomes a highly performing material [3].

Since concrete has been traditionally used for its compressive strength, most research has been done on the fatigue of concrete subjected to compressive stresses [4]. In the

case of high-cycle fatigue of compressed elements, the cracking process mainly concerns the matrix-aggregate interface. Low-cycle fatigue in compression, that involves few load cycles ($\approx 10^3 \div 10^4$) with high stresses (similar to those induced by earthquakes), causes microcracks in the matrix aggregate interface and additional crack widening in the matrix itself.

The problem of fracture in concrete undergoing cyclic loads has been studied during the last 20 years [5]. In presence of cyclic tensile stresses; concrete damage mainly occurs in the microcracked zone around the crack tip (Fracture Process Zone, FPZ; Figure 1) [6]. As a consequence, the behaviour of concrete structural elements subjected to low-cycle fatigue in tension or bending can be correctly assessed only if the presence of FPZ is taken into account [7]. For this reason, Plizzari and co-workers [8] performed fatigue tests on cracked specimens.

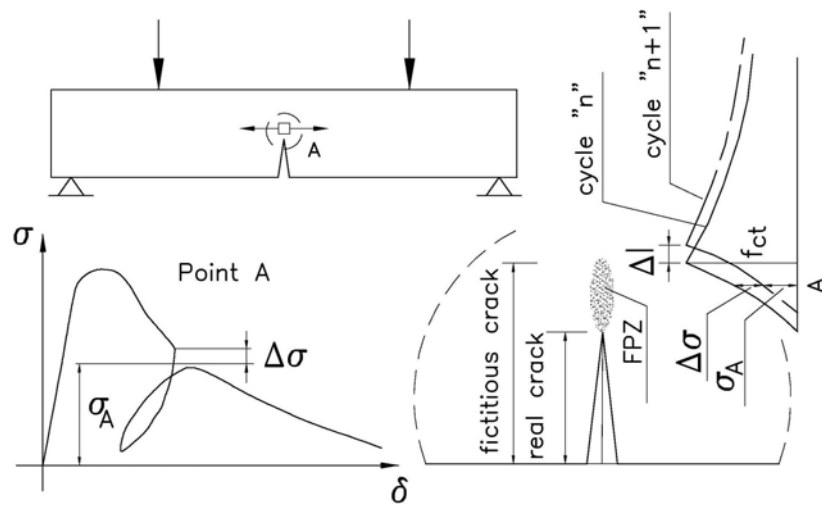

Figure 1. Stress distribution along the fracture process zone in concrete specimens under cyclic loading.

Experimental results have shown that the fatigue life of SFRCs is mainly controlled by two fundamental parameters [9]:

- the crack growth rate under cyclic loading;
- the material toughness (post-cracking strength).

The first one is essentially governed by the steel fibre-concrete bond while the second one to type, geometry and content of the fibre reinforcement.

The toughness increase may be optimised by a suitable design of steel fibre reinforcement. In fact recent investigations have shown that the combination of different fibre types (Hybrid Fibre Reinforced Concrete, HyFRC) provide a higher toughness [10]. In a Hybrid system, micro-fibres should provide reinforcement mechanisms at small to medium crack openings while macro-fibres would carry stresses across cracks at medium to large crack openings. Furthermore micro-fibres can be active as bridging mechanism over the micro-cracks surrounding macro-fibre and cause synergistic effects in the composite.

In this study the benefits by a combination of micro and macro steel-fibres are evaluated under static and fatigue tests carried out on 4PB beams and cylinders under direct tension, respectively. The results show that the mixture of fibres allows a better control of the dynamic crack development.

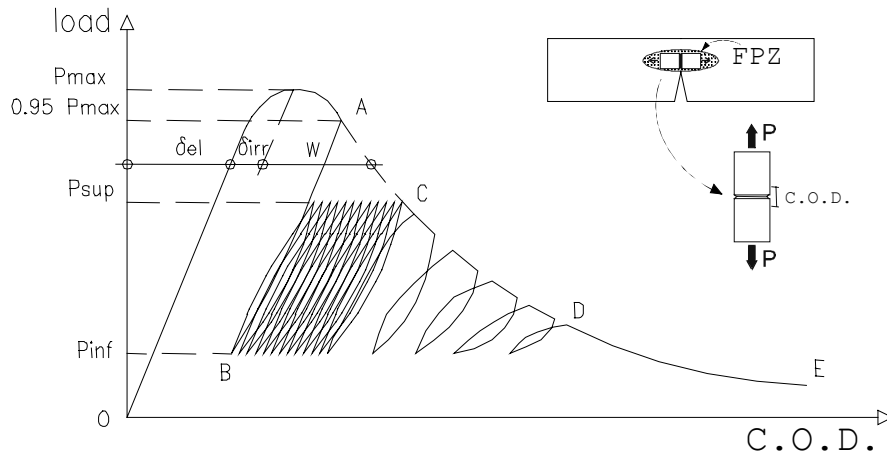

Figure 1. Fatigue behaviour of Fibre Reinforced Concrete.

EXPERIMENTAL SET-UP

Specimen geometries

Static behaviour of Hybrid Fibre Reinforced Concrete was investigated by performing four point bending tests on notched beams with a length of 600 mm and a square section with a side of 150 mm (Figure 2a). The notch had a triangular tip and a depth of 45 mm. The cyclic tensile tests were performed on cylindrical specimens with height of 210 mm and diameter of 78 mm, which were cut out with a diamond saw from a block of concrete to obtain more representative specimens (by reducing the possible fibre orientation that may occur in cylindrical forms). To acquire the stress-crack opening relationship and to prevent the cylinders from failing close to a glued surface, a triangularly shaped notch was made in the middle section, by mechanical turning, to a depth of 4 mm (about 5% of the specimen diameter); this reduced the middle section to 72 mm diameter size (Figure2b).

Materials

Ten types of Fibre Reinforced Concrete with the same matrix were designed for beam and cylindrical specimens. The concrete matrix had a water-cement ratio of 0.45, a cement content (CEM II/A-LL 42.5R according to EN 197-1) of 400 kg/m³, 3.7 litre/m³ of sulphonated formaldehyde condensate based superplasticizer, and 1830 kg/m³ of siliceous aggregates with a maximum size of 16 mm and a grain size distribution close to the Bolomey curve. To obtain the same concrete workability, the content of

superplasticizer was increased up to 10 litres/m³ when the fibres were added to the mixture.

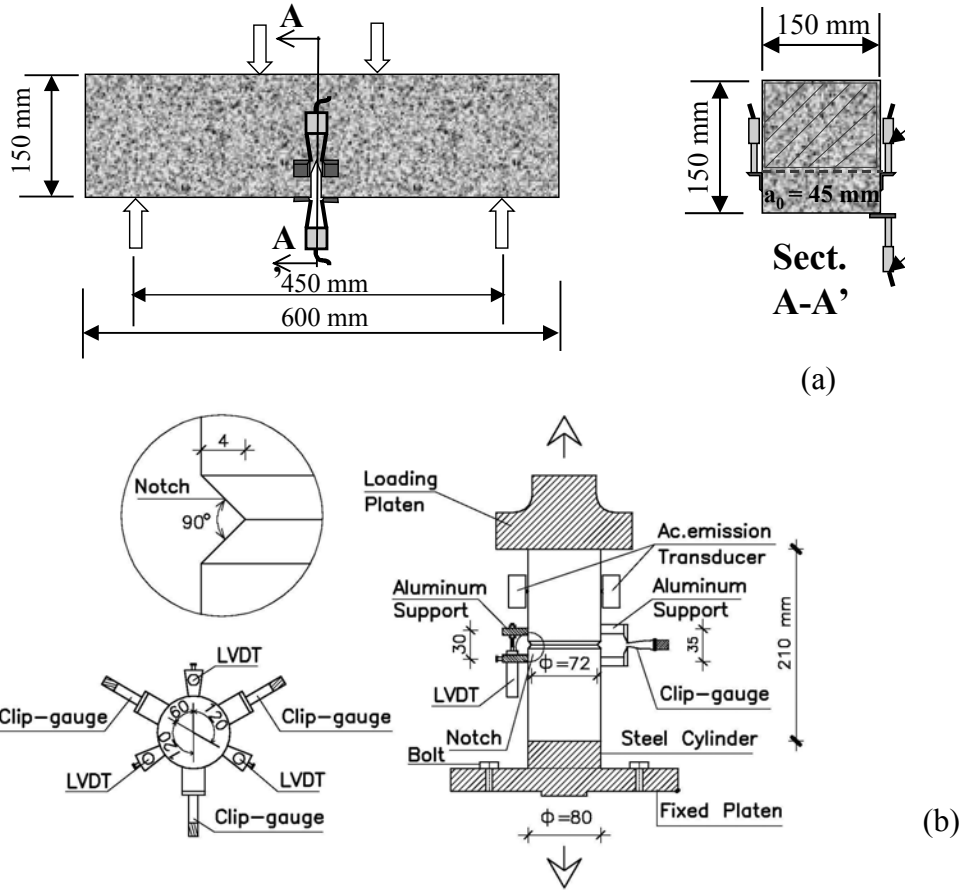

Figure 2. Specimen geometry for bending static tests (a) and tensile cyclic tests (b).

In Table 1 the geometrical and mechanical characteristics of the four types of steel fibres used in this research are reported. The fibres are conventionally classified as macro, meso or micro according to their diameter.

Table 1. Geometrical and mechanical properties of the steel fibres.

Type of steel fibre	Length l_f [mm]	Diameter ϕ_f [mm]	Aspect ratio L/ϕ	Tensile strength f_{ft} [MPa]	Shape
Macro	30	0.60	50	1200	Hooked
Meso1	20	0.40	50	1100	Straight
Meso 2	10	0.40	25	1100	Straight
Micro	12	0.18	66.6	1800	Straight

Table 2 reports, for the ten materials designed for this research, the fibre combinations, the compressive strength after 28 days of curing and the slump values. It can be noticed that four materials are reinforced with a single type of fibre, while five concretes are reinforced with a hybrid combination of macro-fibres and meso or micro-fibres. However, the total volume fraction of fibres was kept constant and equal to 0.64% (50 kg/m³) in all cases. It should be observed that the low fibre content does not affect the compressive strength of hardened concrete.

Table 2. Fibre combinations, compressive strength and slump for the materials adopted.

Concrete type	Volume fraction of fibres (V_f)				Compr. Strength $f_{c,cube}$ [MPa]	Slump [mm]
	[%]					
	Macro	Meso1	Meso2	Micro		
Plain concrete	-	-	-	-	51	130
Macro-FRC (2)	0.64	-	-	-	54	190
Meso1-FRC (8)	-	0.64	-	-	55	190
Meso2-FRC (3)	-	-	0.64	-	53	130
Micro-FRC (6)	-	-	-	0.64	56	140
HyFRC1 (9)	0.32	0.32	-	-	56	190
HyFRC2 (4)	0.32	-	-	0.32	56	190
HyFRC3 (7)	0.32	-	0.32	-	56	200

Testing machine and instrumentation

Both bending and uniaxial tensile tests were carried out by using a very stiff closed loop testing machine. The load was applied by a hydraulic double acting piston without traditional seals to avoid the static friction that takes place during the reversal of piston stroke direction in the cyclic tests. A moog servo-valve with a high dynamic response characteristics (400 Hz) was used as actuator of the control loop and was piloted by a current signal (0-10 mA) coming from a PID controller where the feedback signal was compared with the reference signal generated by a software developed for the tests [5].

The beam specimens were suitably instrumented to measure the Crack Tip Opening Displacement (CTOD) and the Load Point Displacement (LPD) by means of inductive transducers LVDTs (Linear Variable Differential Transformer); in addition, a resistance full-bridge displacement transducer (clip-gauge) was used to measure the Crack Mouth Opening Displacement (CMOD), whose signal was also used as feed back quantity (Fig. 2a).

The cylindrical specimens were instrumented to measure the Crack Opening Displacement (COD) that was acquired by three LVDTs placed radially at 120°(Fig. 2b). In addition, three clip-gauges were equally spaced between the three LVDTs. The analogic average signal of the three clip-gauges was used as feed back quantity in the closed-control-loop.

The rigid coupling of the cylindrical specimens to the loading system was obtained by using two loading plates (Fig. 2b). The specimens were bounded to the plates by an

epoxy resin; the plates were fixed to the loading system. The bottom plate was fixed to the testing machine by four bolts to provide a very rigid constraint. The upper plate was screwed to a threaded bolt having the role of transferring the tension to a reversible load cell with a load capacity of 200 kN.

Loading modalities

Static tests were performed by monotonically increasing the CMOD. For the fatigue tests, four stages of loading were planned with the aim of monitoring the crack growth development in concrete during the test (Figure 1) [8].

- In the first stage (OAB of Figure 1), a constant displacement rate (approx 25×10^{-3} m-s⁻¹) was imposed up to the peak load. When the load dropped to $\approx 95\%$ of the peak load and then a FPZ was present at notch tip, the specimen was unloaded with the same displacement rate up to preset lower limit P_{inf} (point B of Figure 3).
- In the second stage (BC of Figure 1), the controlled quantity (COD) was cycled at a chosen frequency (0.5 Hz); the inversion of the reference signal was made by the software whenever the upper and lower load limits (P_{sup} and P_{inf} , respectively 85% and 35% of P_{max}) were reached. The initial quasi-static stage allowed the direct measurement of the actual tensile-strength of the specimens subjected to cyclic loads. The software was programmed to detect the intersection of the envelope curve (ACDE) which is the locus of broken curves joining the end of a reloading curve to the start of subsequent unloading curve (Figure 1).
- In the third stage (CD), the cyclic loading continued further by imposing the inversion of the feed-back signal (COD) whenever the load, after reaching the envelope curve, dropped to a preset fraction of P_{sup} . This stage ended when the max load, detected on the envelope curve, became lower than a preset fraction of P_{inf} .
- In the fourth stage (DE), a monotonic increase of the COD is imposed as long as the load drops to 1% of P_{max} ; at this point the test is stopped.

RESULTS AND DISCUSSION

Figure 4 shows typical experimental results from static tests on beams with a single fibre (Fig. 4a) and with hybrid fibres (Fig. 4b). The diagrams show the nominal stress (σ_N , evaluated on the uncracked area of the notched section by assuming a linear-stress distribution) versus the CTOD; it can be noticed the higher toughness of microfibres for smaller crack openings (CTOD < 800 μm) while the macrofibres show a better performance for larger values of CTOD (Fig. 4a). Microfibres also increase the peak load while the mesofibres with the lowest aspect ratio (Meso 2) exhibit the worst performance.

If one excludes a single specimen HyFRC2 that has twice the number of fibres in the cracked section, specimens HyFRC1 with macro fibres mixed with mesofibres (having the higher aspect ratio) have a higher toughness. When micro and macro fibres are mixing in a normal strength concrete matrix, a lower toughness was obtained.

Figure 5 shows typical experimental results from uniaxial tensile tests on cylinders in terms of load versus COD. For the sake of comparisons, a reference static test was also performed on a cylinder of plain concrete (Fig. 4a).

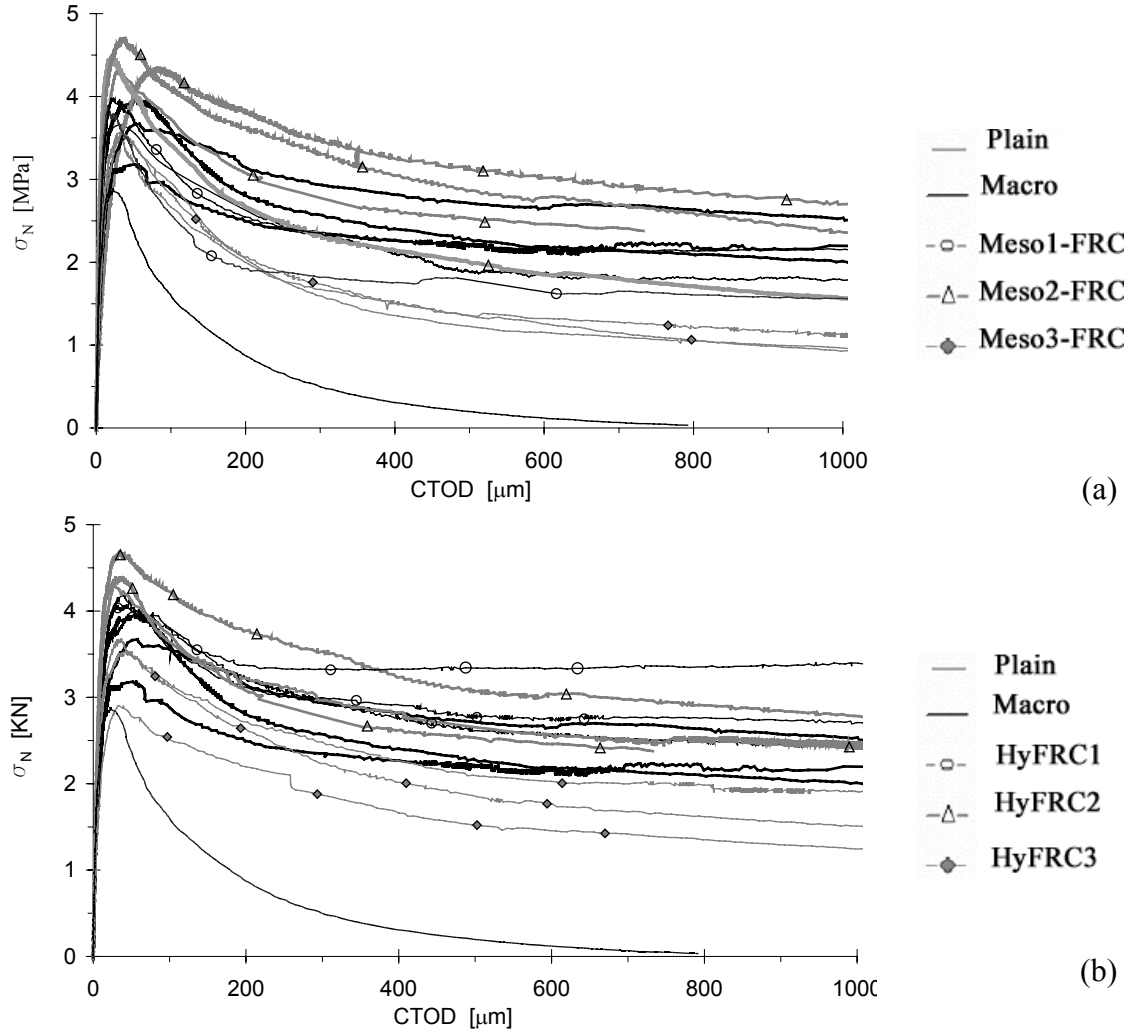

Figure 3. Typical experimental results from static tests on specimens with a single type of fibre (a) and with hybrid fibres (b).

Experimental results from fatigue tests on specimens with macrofibres only are shown in Figure 4b and the total number of cycles is reported in Figure 4d. Because of the very high upper load level (85% of P_{\max}) very few cycles could be applied to the specimen with the exception of specimen Macro-A that was characterizes by a higher number of fibres in the cracked area (Fig. 5a and 5b). The expected number of fibres that bridge the crack section can be evaluated assuming a uniform 3D distribution of steel fibre according to [12]:

$$N = \alpha \cdot \frac{V_f \cdot A_c}{2 \cdot A_f} \quad (1)$$

where N is the number of expected fibres, A_c is the concrete cross section, A_f is the fibre cross section area, α is a constant that depends on the distribution of the fibres and it is equal as 0.5 for uniformly distributed fibres (the theoretical numbers of fibres bridging the cross section for the materials adopted is reported in Figure 4d). This large scatter of experimental results was somehow expected because of the low volume fraction of fibres adopted. Results from hybrid fibres (made of 0.32% of Macro fibres and 0.32% of Meso1 fibres) are shown in Figure 5c; it can be noticed the slightly higher number of cycles and, in particular, the lower scatter of the experimental results (in term of number of cycles). In fact, the smaller diameter of meso (and micro) fibres favours a more uniform fibre distribution. It was already found the remarkable influence of the fibre density in the cracked area; however, this parameter is even more important for fatigue behaviour.

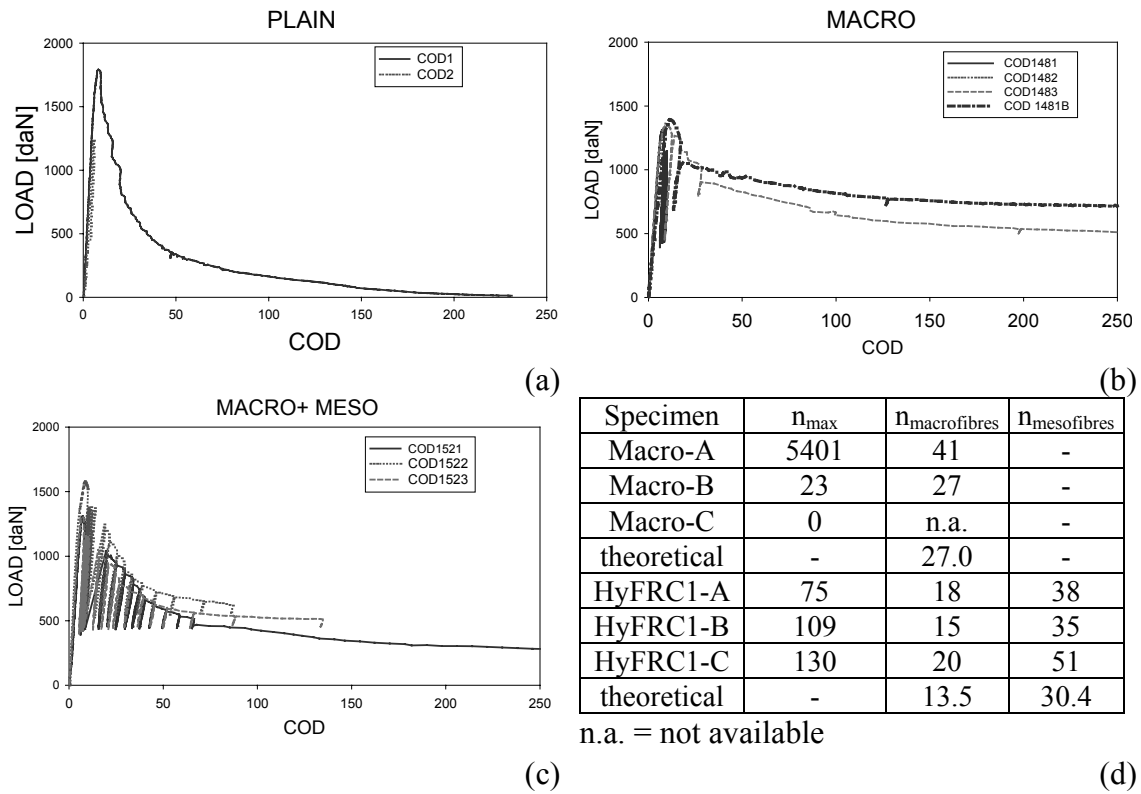

Figure 4. Experimental results from uniaxial tensile tests: static test on plain concrete (a); cyclic tests on cylinders with macrofibres (b) and cyclic tests on cylinders with hybrid fibres (c); maximum number of cycles (n_{max}) and of fibres crossing the cracked section (d).

CONCLUDING REMARKS

The main results can be summarized as follows:

1. Static tests show that the combination of steel fibres of different sizes show synergistic effects in terms of material toughness. Micro fibres increase the peak load from bending tests as well as the post-cracking strength for small crack openings. This synergy is even more significant if one considers that microfibrils also reduces crack openings due to plastic shrinkage.
2. Early results from cyclic uniaxial tensile tests show the contribution of mesofibres in terms of maximum number of cycles. However, it is probably more significant the reduction of the scatter of experimental results because of the more uniform fibre distribution in the cracked area. This was already know from recent experimental results but is probably even more important for fatigue behaviour. The use of short fibres beside long fibres may remarkably help the high scatter of experimental results that is typically observed in fatigue tests.

ACKNOWLEDGEMENTS

The support from Dr Luigi Cassar, director of the CTG Research and Development Department, is gratefully acknowledged. A special acknowledgement goes to Ing. Stefania La Porta for the help in performing the static test and reducing data.

REFERENCES

1. Shah, S.P., Chandra, S. (1970) *ACI Journal, Proceedings* **67**, 816-825.
2. Yin, W., Hsu, T.T.C. (1974) *ACI Journal, Proceedings* **71**, 97-121.
3. Banthia, N. (1990) *Canadian Journal of Civil Engineering* **17**, 610-620.
4. Holmen, J.O. (1979) Doctoral thesis, NTH Trondheim, Norway.
5. Reinhardt, H.W., Cornelissen, H.A.W. (1984) *Cement and Concrete Research* **14**, 263-270.
6. Hillerborg, A., Modèer, M., Petersson, P.E (1976) *Cement and Concrete Research*, **6**, 773-782.
7. Slowik V., Plizzari G.A., Saouma V. (1996) *ACI Materials Journal* **93(3)**, 272-283.
8. Plizzari G. A., Cangiano S., Alleruzzo S. (1997) *Fatigue & Fracture of Engineering Materials & Structures* **20(8)**, 1195-1206.
9. Plizzari, G.A., Cangiano, S., Cere, N. (2000) *ACI Materials Journ.* **97 (2)**, 182-192.
10. Banthia, N., Nandakumar N. (2003) *J. of Cement Composites* **25(1)**, 3-9.
11. UNI 10039 (2003) *Italian Board for Standardisation*.
12. Wang, Y. , Li, V. C., Backer S. (1989), *International Journal of Cement Composites and Lightweight Concrete* **20(3)**, 265-274.