

A NLFM METHOD FOR THE PREDICTION OF SLABS ON GRADE BEHAVIOUR

B. BELLETTI¹, P. BERNARDI¹, A. MEDA², G. PLIZZARI²

¹ Department of Civil and Environmental Engineering and Architecture University, of Parma, Italy.

² Department of Engineering Design and Technologies, University of Bergamo, Italy.

ABSTRACT

An effective NLFE method for the analysis up to failure of slabs on grade is presented herein. In order to better evaluate the role played by the fibres with respect to conventional reinforcement, previous experiments on full-scale slabs on grade have been numerically simulated to reproduce the actual slab behaviour up to failure and to provide some useful information for design purposes.

The adopted numerical procedure is based on the implementation of the PARC stiffness matrix into a multi-purpose FE Code (ABAQUS), which allows for the definition of specific material's constitutive relationship by compiling users' subroutines. The adopted constitutive model includes a micro-mechanics based constitutive model for the FRC material, which takes separately into account the bridging action due to fibres and aggregates and allows for the formation of a secondary cracking, not necessary perpendicular to primary cracking, in the concrete strut between two consecutive cracks. This last important extension of the PARC model allows for more realistic numerical simulations of the slab behaviour, especially for the ultimate limit state.

Finally, some design considerations could also be introduced by comparing the numerical response of slabs characterised by the same geometry and loading conditions but a different reinforcement arrangement. In particular, the behaviour of concrete slabs reinforced by steel fibres only, by steel bars only or by steel bars and fibres together was investigated.

1 INTRODUCTION

Non Linear Fracture Mechanics (NLFM) represents a powerful tools for analyzing Steel Fibre Reinforced Concrete (SFRC) slabs on grade; in fact, because of the stress redistribution, possible in these statically indeterminate structures, the bearing capacity can remarkably increase after reaching the ultimate strain up the formation of a collapse mechanism [1,2]. This evidences that slab behaviour is highly influenced by the crack propagation and underlines the importance of a fibre reinforcement. In fact, concrete toughness is significantly increased by steel fibres that enhance concrete toughness and may substitute (partially or totally) conventional reinforcement.

Design methods for slabs on grade are traditionally based on an elastic approach [3]. In this way the above mentioned stress-redistribution is not considered and the bearing capacity is often dramatically underestimated. More suitable methods are those based on the yield line theory. However, these methods can be used only when simple load condition are present and can give an accurate prediction of the slab behaviour when a pure elasto-plastic sectional response is present. This is possible when conventional reinforcement is adopted, whereas it is not so accurate with fibre reinforcement since SFRC usually has a softening post cracking behaviour [4].

The use of a NLFM method for modelling concrete slabs on grade with different types of reinforcement is presented herein. In particular, it is here considered: the use of conventional reinforcement (steel mesh), of fibre reinforcement as well as the use of both types of reinforcement together. The analysis were carried out by means of a commercial FE program (ABAQUS) where suitable subrutines were defined for apply the NLFM approach, based on the PARC model.

The validation of the method was firstly obtained by simulating previous experiments on full-scale slabs subjected to different loading conditions [5].

The numerical results provides useful information on the role played by fibre reinforcement, particularly when used in addition to a steel mesh.

2 REVIEW OF THE EXPERIMENTS ON FULL-SCALE SLABS ON GRADE

Experiments were carried out on full scale slabs on grade [5]. Square slabs with a side of 3 m and a thickness of 150 mm were adopted (Figure 1). The slabs were placed on 64 steel springs to simulate an elastic subgrade (Winkler soil) with a constant typical for industrial pavements ($k \approx 0.08 \text{ N/mm}^3$). The target stiffness was obtained by placing the springs at a distance of 375 mm. Two different loading cases have been considered in the experiments: a point load placed in the centre (Figure 1) or two single loads placed along a median line [5].



Figure 1: Slab with the load frame and the instrumentation for a single load [5].

All the slabs were cast with the same concrete ($f_c = 30 \text{ MPa}$), made of cement CEM 42.5R type II/A-LL 42.5 and a natural river gravel, with a rounded shape and a maximum diameter of 15 mm.

When a single load was used, slabs with 30 kg/m^3 (volume fraction of 0.38 %) of fibres (length = 50 mm; diameter = 1 mm) or conventional reinforcement (welded mesh $\phi 8 @ 200 \times 200 \text{ mm}$ (corresponding to a volume fraction of 0.33%), were tested. In the case of 2 single point loads, only a fibre reinforced slab was adopted. Further details on the experiments can be found in [5].

3 NUMERICAL CONSTITUTIVE MODEL

The stiffness matrix which has been adopted for non-linear finite element analyses refers to the PARC constitutive model [6]. This model is able to describe the non-linear mechanical behaviour of uncracked and cracked Reinforced Concrete or SFRC subjected to plane stresses.

In the uncracked stage (1,2), concrete behaves as a non-linear orthotropic material, with orthotropic axes assumed coincident with principal strain directions. The effective biaxial state of stress is described by means of equivalent uniaxial curves, with peak stress values determined through an analytical biaxial strength envelope as suggested by Kupfer et al. [7,8].

After maximum principal stress becomes greater than concrete tensile strength, first crack occurs and a different stiffness matrix is considered, which takes into account the softening of cracked concrete in compression, the aggregate interlock and the non-linear fracture mechanics for SFRC, while the contributions of dowel action and tension stiffening are added in the case of reinforced concrete. Primary cracks are assumed as fixed and equally spaced at a distance a_m , equal to fibre length in the case of SFRC and equal to transmission length in case of RC. To reproduce the actual slab behaviour, a considerable effect on the global response has been observed when the model included the possibility of having secondary cracks. For this reason, in all the numerical analyses the double crack formulation of the PARC model for SFRC has been used [9], and here it has also been adapted to conventional reinforced concrete. Secondary cracks form when the stress field in the strut between two adjacent cracks produces a maximum principal stress greater than concrete tensile strength. The formulation is based on total strain decomposition into strain due to primary cracks and strain due to secondary cracks, while the stress field is the same both for primary and

secondary cracks that are assumed to act independently, with the same value of crack spacing; in particular, when secondary cracks open, primary cracks are not subjected to closing and re-opening.

4 NON-LINEAR FINITE ELEMENT ANALYSIS RESULTS

The PARC stiffness matrix has been implemented into the FE Code ABAQUS to perform non-linear finite element analyses. The slabs have been subdivided into a mesh of isoparametric multi-layered shell elements (Figure 2). To reproduce the non-linear response of the springs, a tri-linear law was adopted, characterised by a no-tension behaviour and a bilinear shape in compression. As can be observed in Figures 3a and 4a, a good correlation between numerical and experimental results was obtained through the proposed procedure for unreinforced slabs as well as for slabs reinforced either with steel fibres or with a welded mesh, for the different loading conditions. As can be observed, both the global response and the ultimate load (Table 1) are well represented by the non-linear model (the ultimate load was associated to the asymptotic trend of the width of primary cracks). Since the results obtained from the performed numerical analyses proved to be reliable, other simulations were carried out to study the effect of the slab reinforcement on its global response. For each loading condition, four different types of reinforcement were considered: plain concrete (C), steel fibre reinforced concrete (SFRC), concrete reinforced with a steel mesh (RC) and steel fibre reinforced concrete with a steel mesh (SFRC+RC).

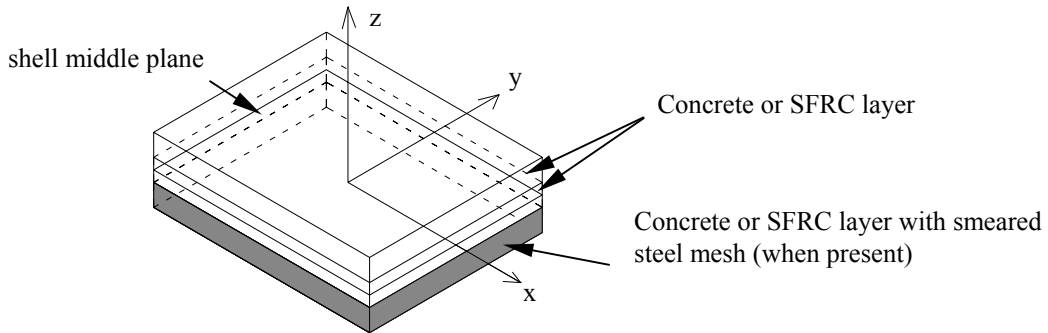

Figure 2: Four-node, reduced integration, isoparametric three-layered shell element adopted in the FE analyses with the considered materials layers.

Table 1 shows the numerically determined failure loads of reinforced slabs normalized to the ultimate load obtained from the plain concrete slab; it clearly shows that the failure load reached by SFRC slabs is less than the corresponding ultimate load of RC slabs for both loading conditions (see also Figures 3b and 4b). However, it should be noticed that the load increment of the slab with the welded mesh is higher for the slab under a single load (Figure 3b) than for slabs loaded in two points (Figure 4b). The better performance of the RC slabs under a single load was somehow expected since the reinforcement was placed at the bottom layer, where the tensile stresses are present. Different is the case of slabs loaded in two points where tensile stresses are also present at the top surface (for the assumed distance between the load points) where only fibre reinforcement is present (see also Figures 5a and 6a that show the flow of the maximum principal stresses).

The presence of both types of reinforcement (welded mesh and fibres) increased both slab strength and ductility. It should be underlined that, in addition to the bearing capacity which is shown here, fibre reinforcement also reduces cracking phenomena due to shrinkage or thermal effects.

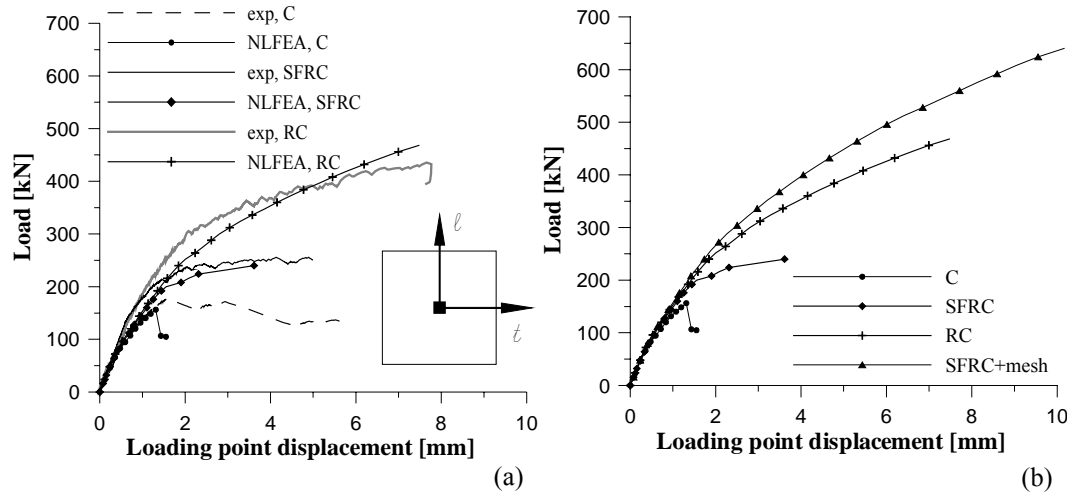

Figure 3: Slabs under a single load: comparison between numerical and experimental load-displacement curves (a); numerical curves of slabs characterised by a different reinforcement (b).

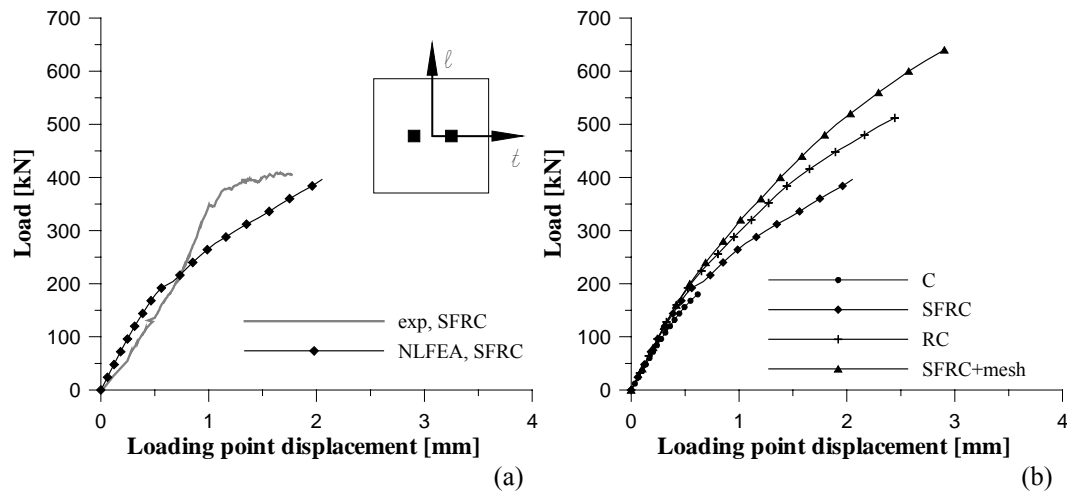

Figure 4: Slab under two loading points: comparisons between numerical and experimental load-displacement curves (a); numerical curves of slabs characterised by a different reinforcement (b).

From Table 1 it can also be observed that the load increase (F_u/F_u^C) of the slab with fibres and welded mesh is higher than the slab with welded mesh only when a single point load is applied. This can be explained by observing the trend of the longitudinal rebar strains in the crack (Figure 7); the tougher concrete response due to the fibres causes lower rebar strains for the same load level, and a consequent crack opening reduction, which is much more effective with a single load, where only the bottom side is subjected to tensile stresses. When two point loads are present, the maximum crack opening and the rebar strain at failure are almost the same (for the two types of reinforcement) because the slab is subjected to tensile stresses both at the bottom and top side

(Figure 7). One should note that, for all the slabs, the fibres contribution becomes significant when the rebar strain is higher than the yielding strain; the latter corresponds a crack opening of about 0.2 mm. In fact, the adopted residual stresses vs. crack opening relationship [8], confirms that the fibre bridging action is fully developed only when crack opening reaches such a value.

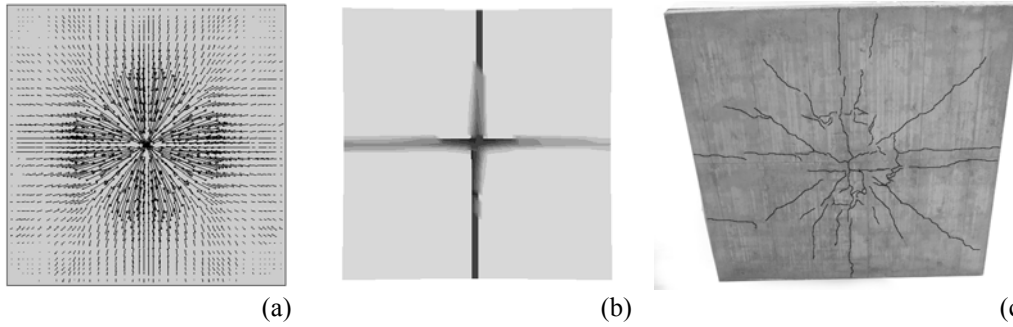

Figure 5: RC slab loaded in its centre point: (a) numerical flow of the minimum principal stress directions; comparison between (b) the numerical and (c) the corresponding experimental final crack pattern at the bottom side of the slab.

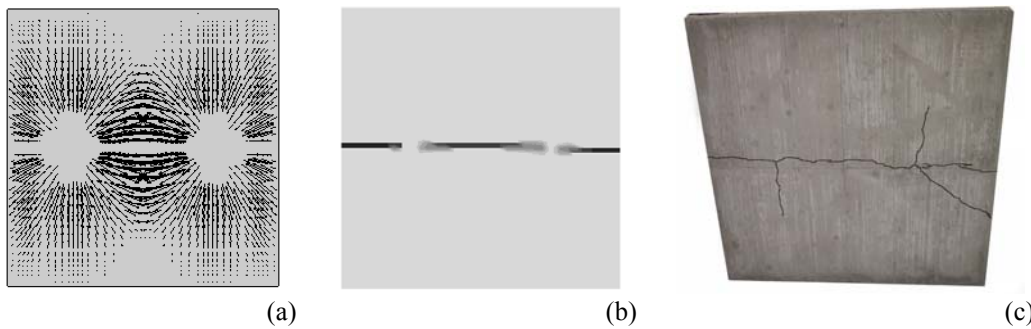

Figure 6: SFRC slab loaded under two single loads: (a) numerical flow of the maximum principal stress directions in the upper side of the slab; comparison between (b) the numerical and (c) the experimental final crack pattern at the bottom side of the slab.

Table 1: Comparisons between numerical and experimental failure loads for the analysed slabs.

Loading condition	Reinforcement type	Failure load (F_u) (kN)		$F_{u,NLFEA} / F_{u,NLFEA}^C$
		$F_{u,exp}$ (kN)	$F_{u,NLFEA}$ (kN)	
Single point	C	177.0	156	1.00
Single point	SFRC	238.6	240.0	1.53
Single point	RC	425.8	468	3.00
Single point	SFRC+RC	-	640	4.1
Two points	C	-	180	1.00
Two points	SFRC	-	408	2.26
Two points	RC	401.2	512	2.84
Two points	SFRC+RC	-	640	3.56

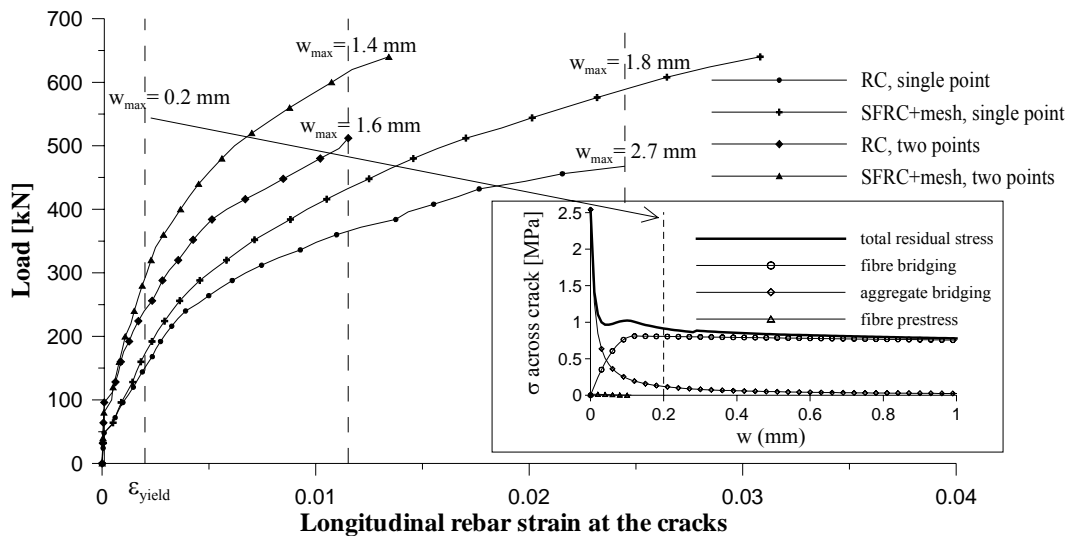

Figure 7: Load versus longitudinal rebar strain at the cracks under the loading point and adopted constitutive model for SFRC.

Figures 5b and 5c show the good agreement of the final crack pattern of the slab with a single load and conventional reinforcement, as obtained from the numerical analysis and from the experiments respectively. The same good agreement was obtained for all the other slabs; as an example, Figures 6b and 6c show the comparison for the SFRC slab under two load points.

6 REFERENCES

- [1] Falkner, H., Huang, Z., and Teutsch, M., 'Comparative Study of Plain and Steel Fiber Reinforced Concrete Ground Slabs', *CONCRETE INTERNATIONAL*, 17(1), 45-51, 1995.
- [2] Meda, A., and Plizzari, G. A., 'New Design Approach for Steel Fiber-Reinforced Concrete Slabs-on-Ground Based on Fracture Mechanics', *ACI STRUCTURAL JOURNAL*, 101(3), 298-303, 2004.
- [3] Westergaard, H.M., 'Stresses in concrete pavements computed by theoretical analysis', *PUBLIC ROADS*, 25-35, 7(2), 1926.
- [4] Meda, A., 'On the extension of the yield-line method to the design of SFRC slabs on grade', *STUDIES AND RESEARCHES*, Politecnico di Milano, 24, 223-239, 2003.
- [5] Sorelli, L., Meda, A., Plizzari, G.A., and Rossi, B., 'Experimental investigation on slabs on grade: steel fibres vs. conventional reinforcement', *Proceedings of RILEM Symposium BEFIB 2004*, Varenna (Italy), 20-22 September 2004, to be published.
- [6] Belletti, B., Cerioni, R., Iori, I., 'A physical approach for reinforced concrete (PARC) membrane elements', *ASCE JOURNAL OF STRUCTURAL ENGINEERING*, 127(12), 1414-1426, 2001.
- [7] Kupfer, H., Hilsdorf, H.K., Rusch, H., 'Behavior of Concrete Under Biaxial Stresses.', *PROCEEDINGS OF ACI JOURNAL*, 66(8), 656-666, 1969.
- [8] Belletti, B., Bernardi, P., Cerioni, R., Iori, I., 'On a Fibre-Reinforced-Concrete Constitutive Model for NLFE Analysis', *STUDIES AND RESEARCHES*, Politecnico di Milano, 24, 2003.
- [9] Belletti, B., Cerioni, R., Meda, A., Plizzari, G.A., 'Experimental and numerical analyses of FRC slabs on grade', *Proceedings of FRAMCOS5 Conference*, Vail Colorado, 973-980, 2004.